

# Polyform® APBXL Aqua Series

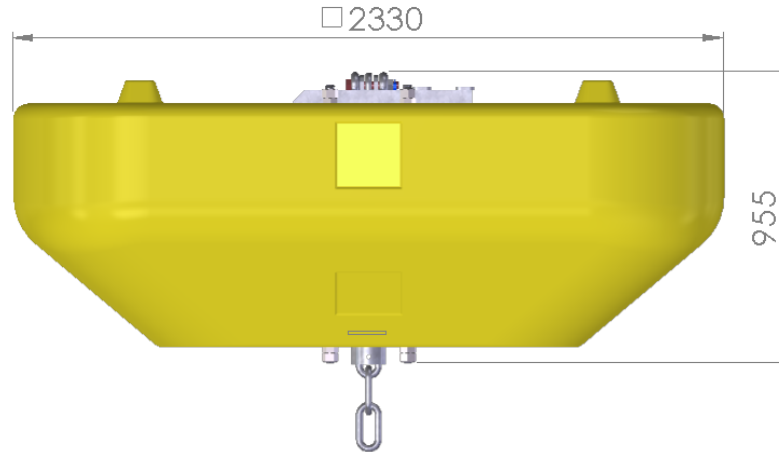

Proudly made by  
The Originator of  
Modern Plastic Buoys

## Product information



### POLYFORM® OF NORWAY

The APBXL 3T Aqua buoy is rotomolded from polyethylene (PE) and filled with polystyrene foam (EPS), designed for surface use and equipped with yellow, daylight reflective tapes on all 4 sides. In addition to the continuous chain through the center, the buoy is secured with 4 full-length hot dip galvanized steel bolts.

The APBXL-series represents a modular series of buoys, designed for surface or for sub-surface use, rotomolded from polyethylene (PE) and filled with polystyrene foam (EPS), polyurethane foam (PUR) or other materials depending on the application. The steel armatures and chain vary from application to application depending on whether it is for aquaculture, offshore, surface, sub-surface or other installations. The buoys are designed to form a modular system and individual sections can therefore be added or, if necessary be removed from the assembly, to adapt to different buoyancy needs. The buoys include an integrated fixture for light and different other equipment easily to be mounted on the topside of the buoy.

### Polyform AS

Polyform AS is a world leading manufacturer of buoys fenders and floats, and the originator of the modern inflatable plastic buoy. The company is registered in Norway and situated in Ålesund at the north-western coast of Norway, and benefits from being located in one of the world's most innovative maritime environments.

The product range of Polyform AS consists of:

- Inflatable buoys and fenders made from soft Vinyl plastics.
- Purse Seine Floats, buoys and marina fenders made from BACELL closed cell foam.
- Hard-shell buoys and pontoon floats made from PE and filled with foam

**POLYFORM AS**  
Tverrvegen 37  
N-6020 Ålesund  
Norway

+47 70 17 25 50  
+47 70 14 76 36  
mail@polyform.no  
www.polyform.no

Article	APBXL 3T aqua
Length	2330 mm
Width	2330 mm
Height	955 mm
Wall thickness	10 mm
Weight (nominal)	345 Kg
Gross volume	3340 L
Buoyancy	3000 Kg
Recommended normal load	1500 Kg

## Technical information

Breaking load Chain	475 KN
Breaking load Shackle	600 KN
Buoy body material description	
Material	LLPE
Hardness, shore D	57
Tensile strength	17,5 MPa
Ultimate Elongation	650%
Recommended min temp.	-25°C
Recommended max temp.	40°C
Temp. not to be exceeded	50°C
Specific gravity	0,94
Foam core material description	
Material	EPS
Density	>25 Kg/m <sup>3</sup>
Compressive strength	50 KPa

### PRODUCT CERTIFICATE



Complies with the requirements for strength and safety according to **Marine fish farms NS9415** (Norwegian Standard)

For all measurements, weights and other technical data specified in this data sheet, please allow for a deviation of not less than +/-5%. The illustration may deviate from the actual product.