

Polyform® SMB100 modular buoyancy



Proudly made by
The Originator of
Modern Plastic Buoys

POLYFORM® OF NORWAY

The SMB100 modular buoyancy is made from a rotomolded PE outer shell and filled with polyurethane (PUR) foam, with compressive strength for a variety of depth ratings. The continuous high quality chain is terminated at either end of the buoy by use of hot dip galvanized steel terminating discs that are designed to prevent damage to the buoy. The chain is easily attached by shackle to the anchor line. All wear parts are standard components and can easily be replaced. These modular buoys are designed for submerged and surface use and they can be equipped with four yellow, daylight reflective tapes for better visibility.

Polyform AS

Polyform AS is a world leading manufacturer of buoys fenders and floats, and the originator of the modern inflatable plastic buoy. The company is registered in Norway and situated in Ålesund at the north-western coast of Norway, and benefits from being located in one of the world's most innovative maritime environments.

The product range of Polyform AS consists of:

- Inflatable buoys and fenders made from soft Vinyl plastics.

- Purse Seine Floats, buoys and marina fenders made from BACELL closed cell foam.

- Hard-shell buoys and pontoon floats made from PE and filled with foam

Product information

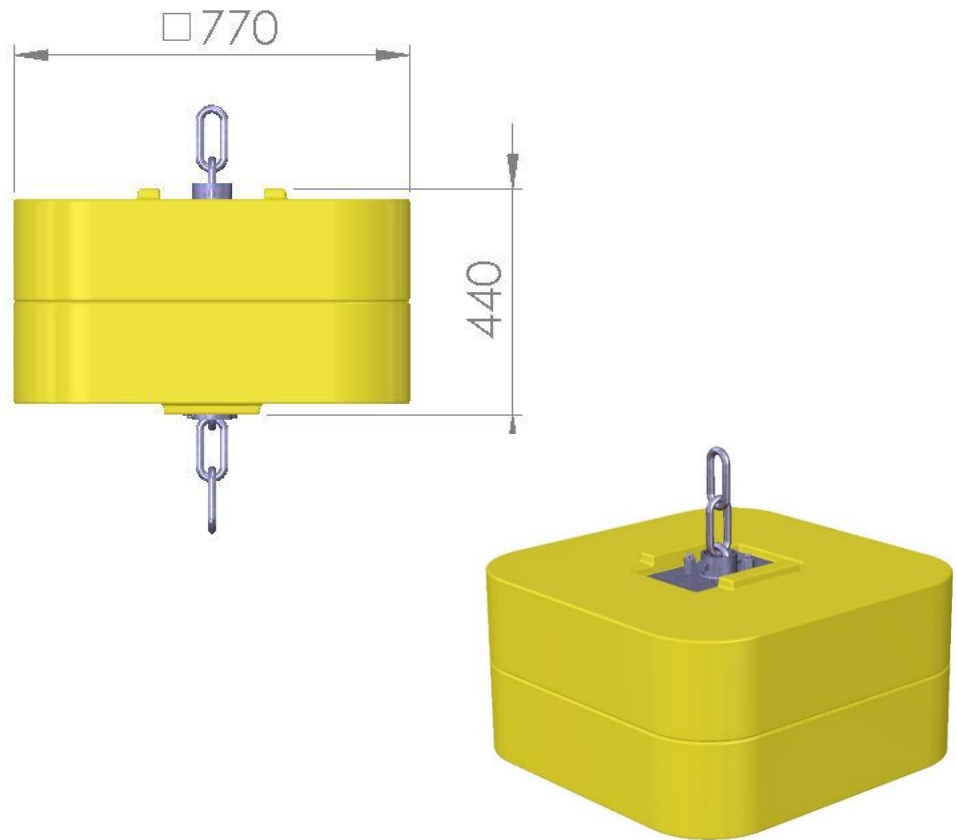

SMB100 - 2 modules

Gross measures	77x77x44 Cm (LxWxH)			
Article no	2602001045	2602010045	2602025045	2602050045
Max depth rating	-10 m	-100 m	-250 m	-500 m
Gross volume	220 L	220 L	220 L	220 L
Weight	46 Kg	68 Kg	89 Kg	115 Kg
Net buoyancy @ depth rating	175 Kg	150 Kg	129 Kg	104 Kg
PU core density	50 Kg/m ³	170 Kg/m ³	280 Kg/m ³	400 Kg/m ³

Technical Information

Breaking load Chain	260 KN
Buoy body material description	
Material	LLPE
Hardness, shore D	57
Tensile strength	17,5 MPa
Ultimate Elongation	650%
Recommended min temp.	-25°C
Recommended max temp.	40°C
Temp. not to be exceeded	50°C
Specific gravity	0,94

For all measurements, weights and other technical data specified in this data sheet, please allow for a deviation of not less than +/-5%. The illustration may deviate from the actual product.

POLYFORM AS

Tverrvegen 37
N-6020 Ålesund
Norway

+47 70 17 25 50
mail@polyform.no
www.polyform.no