

Polyform® APB Aqua Series



Proudly made by
The Originator of
Modern Plastic Buoys

Product information

POLYFORM® OF NORWAY

The APB 3000 Aqua buoy is rotomolded from polyethylene (PE) and filled with polystyrene foam (EPS), designed for surface use and equipped with yellow, daylight reflective tapes on all 4 sides. The buoy is made from two 1500 liter elements. In addition to the continuous chain through the center, the buoy is secured with 4 full-length hot dip galvanized steel bolts.

The APB-series represents a modular series of buoys, designed for surface or for sub-surface use, rotomolded from polyethylene (PE) and filled with polystyrene foam (EPS), polyurethane foam (PUR) or other materials depending on the application. The steel armatures and chain vary from application to application depending on whether it is for aquaculture, offshore, surface, sub-surface or other installations. The buoys are designed to form a modular system and individual sections can therefore be added or, if necessary be removed from the assembly, to adapt to different buoyancy needs. The buoys include an integrated fixture for light and different other equipment easily to be mounted on the topside of the buoy.

Polyform AS

Polyform AS is a world leading manufacturer of buoys fenders and floats, and the originator of the modern inflatable plastic buoy. The company is registered in Norway and situated in Ålesund at the north-western coast of Norway, and benefits from being located in one of the world's most innovative maritime environments.

The product range of Polyform AS consists of:

- Inflatable buoys and fenders made from soft Vinyl plastics.
- Purse Seine Floats, buoys and marina fenders made from BACELL closed cell foam.
- Hard-shell buoys and pontoon floats made from PE and filled with foam

POLYFORM AS
 Tverrvegen 37
 N-6020 Ålesund
 Norway

+47 70 17 25 50
 +47 70 14 76 36
 mail@polyform.no
 www.polyform.no

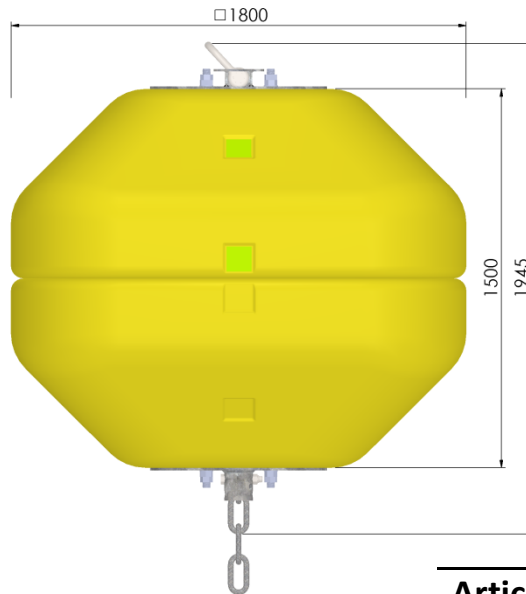

Article	APB 3000 aqua Light
Length	1800 mm
Width	1800 mm
Height	1945 mm
Wall thickness	10 mm
Weight (nominal)	375 Kg
Gross volume	3400 L
Buoyancy	3110 Kg
Recommended normal load	1550 Kg

Technical information

Breaking load Chain	475 KN
Breaking load Shackle	600 KN

Buoy body material description

Material	LLPE
Hardness, shore D	57
Tensile strength	17,5 MPa
Ultimate Elongation	650%
Recommended min temp.	-25°C
Recommended max temp.	40°C
Temp. not to be exceeded	50°C
Specific gravity	0,94

Foam core material description

Material	EPS
Density	25 Kg/m ³
Compressive strength	50 KPa

PRODUCT CERTIFICATE



Complies with the requirements for strength and safety according to **Marine fish farms NS9415** (Norwegian Standard)

For all measurements, weights and other technical data specified in this data sheet, please allow for a deviation of not less than +/-5%. The illustration may deviate from the actual product.